

Our associates will ensure the tool works properly before you leave the store. If you experience issues with the tool while completing your project, simply bring it back to the Tool Rental Center to get a replacement. If you purchase Damage Protection at the time of your rental, you are not responsible for repair costs for tools that break due to normal use.





Operator's Manual

PGD2875



Table of Contents

Introduction.....	2
Safety Warnings	3
Main Parts.....	4
Preparation for Use.....	5
Operating Instructions.....	7
Service and Maintenance.....	8
Troubleshooting.....	12
Key Product Data.....	13
Parts Diagrams.....	14
Warranty.....	19
Contact Info.....	20

Introduction

Thank you for choosing Titan Gas-Powered Post Drivers. The performance of this machine is dependent upon your knowledge of the information contained in this operator's manual and your understanding of the operation and care of the engine installed on your Titan Post Driver.

Your Titan Post Driver comes with a one-year limited manufacturer's warranty (see warranty terms on Page 19 of this manual). We suggest that you read the warranty information and fully understand its coverage and your responsibilities of ownership. To register your Titan Post Driver, simply fill out and return the warranty registration card enclosed with your machine.

Please contact Titan Post Drivers at **(702) 293-4262** for parts or technical questions related to your post driver warranty.



Titan PGD2875 Post Driver

Safety Warnings

1. Always follow proper operation and maintenance instructions.
2. Always use approved Personal Protective Equipment (PPE). Operators and all other persons in the immediate working area must wear protective equipment as well. Noise emitted from the machine while working can reach above 100 decibels, which can also harm others in close proximity. We recommend the following personal protective equipment:
 - a. Class 4 (SLC80 = 22.4 dB) hearing protection or greater
 - b. Impact-resistant eye protection with side guards
 - c. Protective gloves
 - d. Protective boots
3. Always check fastening screws before use. If they are loose, tighten them.
4. Always check the spark plug before use. If it is exposed, it must be covered by a high-voltage cap. Check the flameout line and pipes for damage. If damaged, repair or change them before use.
5. Keep the handle clean and dry.
6. Do not add too much fuel. The fuel level should not exceed the neck of the fuel tank. If accidental overfilling occurs, pour fuel out until the fuel level is within the proper range within the fuel tank. There should not be any fuel on the surface of the machine. ALWAYS wipe your post driver clean after refueling. Only start the post driver after any excess fuel has evaporated completely.
7. After refueling, tighten the fuel lid. Be sure to check for fuel leaks or damage to the fuel tank. If damage is found, turn off the post driver immediately, and do not operate it until the damage is repaired.
8. Never use this post driver inside a building or unventilated area. The engine exhaust contains poisonous carbon monoxide gas that can build up to dangerous levels in closed areas. These fumes can cause unconsciousness or death.
9. Do not use the post driver in adverse weather conditions such as thunderstorms, heavy fog, or strong wind.
10. While operating the post driver, maintain good balance and operate the machine vertically. The operator should stand and operate this machine from the front.
11. Do not operate the post driver with one hand or turn the machine upside down horizontally. ALWAYS use two hands and correct posture when operating the driver.
12. When transporting the post driver, turn it off.
13. Never let your post driver run unattended, and keep unauthorized persons away from the operation area.
14. While operating the post driver, be sure the contact surface of the post is smooth and flat and the diameter of the post is within the limit of the post driver barrel (3.15").
15. Avoid quick acceleration so you do not damage the machine.
16. During operation, be sure the muffler exhaust fumes are pointed away from others. The high-temperature exhaust gas can cause serious injury.
17. To avoid being burned, do not touch the muffler, engine cylinder, barrel, hammer case, gearbox, etc. after operation. These parts will be very hot and can cause serious injury.
18. Gasoline is highly flammable. Therefore, replenish fuel in a well-ventilated area. ALWAYS turn off the engine before refueling.
19. Store fuel in a proper area that is free from fire hazards.
20. Before transport, empty the fuel inside the fuel tank to avoid leakage.
21. Non-professional maintenance staff are prohibited from dismantling this post driver in order to avoid accidents, structural damage of parts, and /or shortened service life.

Main Parts



No.	Part Name	No.	Part Name	No.	Part Name
1	Oil Level Gauge	2	Handle	3	Starter
4	Gas Tank	5	Gas Cap	6	Choke Valve
7	Fuel Bubble	8	Air Filter	9	Positioning Sleeve
10	Dampening Spring	11	Handle Sleeve	12	Grease Cap
13	Hammer Case	14	Serial No. Location	15	Throttle Limit Screw
16	Combination Switch	17	Throttle Switch	18	Stop Switch
19	Throttle Cable	20	Piling Socket	21	Piling Socket Sleeve

Preparations For Use

Installing Inner Pile Head

If the inner pile head (#49) is not pressed on the shock (#43) at this time, you must slide the inner pile head inside the piling socket and match the small side with the shock. Tap the inner pile head a few times to make sure it is connected to the shock. As you start using your machine, the inner pile head will press further on the shock and will not separate again without the use of tools.

Installing Piling Socket Sleeve

Before use, install the correct piling socket sleeve for your application as shown below:

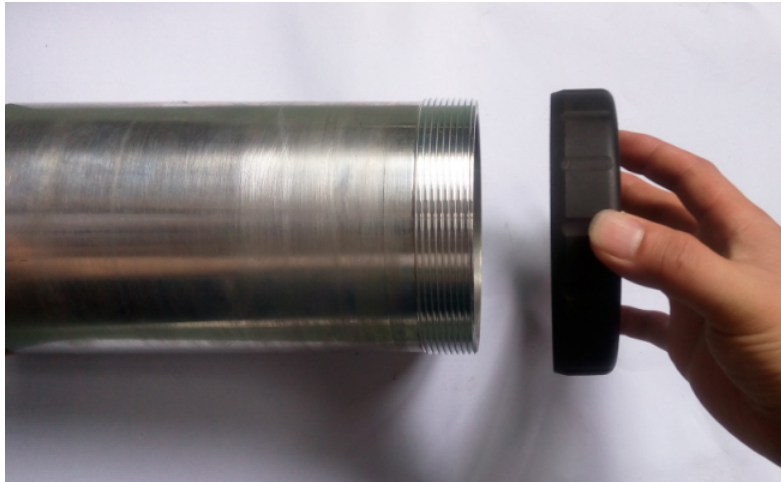

Adding Fuel

1. Always turn the engine off and allow adequate time for it to cool before refueling. Only use unleaded fuel with 86 octane or higher.
2. Never refuel your driver with the engine hot, running, or in an unventilated area. Fuel vapors are extremely flammable and can cause severe injury or death if ignited by a spark or excessive heat from a hot engine.
3. Do not add too much fuel. The fuel level should not exceed the neck of the filler fuel tank. If accidental overfilling occurs, pour fuel out until the fuel level is within the proper range within the fuel tank. There should not be any fuel on the surface of the machine. ALWAYS wipe your post driver clean after refueling. Only start the post driver after any excess fuel has evaporated completely.
4. After refueling, tighten the fuel tank lid.
5. This post driver uses pure gasoline as fuel. Do not use gasoline mixed with oil. This will result in poor starting performance and low function.

Adding Engine Oil

1. Before the first use, drain any oil that might be inside the crankcase, and refill using the bottle of oil that is supplied with your driver. We suggest adding 2.7 US ounces and then checking the oil. Place the oil level gauge back in the oil filler neck, BUT DO NOT SCREW IN WHILE CHECKING THE OIL LEVEL, OR YOU WILL GET A FALSE READING.
2. To avoid damage to the engine, always check the engine oil before starting the driver. Be sure the engine oil level is adequate.
3. For every 10 hours of use, it is necessary to check the oil level.
4. To check the oil, place the driver horizontally. Unscrew the oil level gauge, and check the oil level as shown below. If the oil level is low, add oil. If the oil is dirty, change the oil.

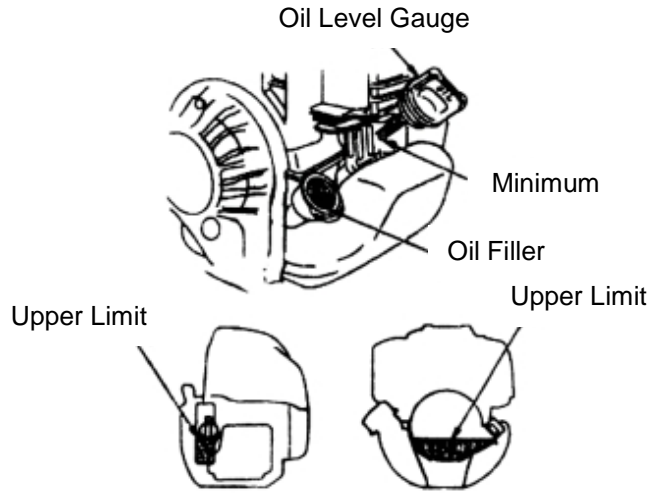

The recommended environmental temperature range of the machine is 5° to 105° F. We recommend the use of SAE 10W-30 engine oil, which equals to API classification SJ. See SAE Engine Oil Consistency Table below.

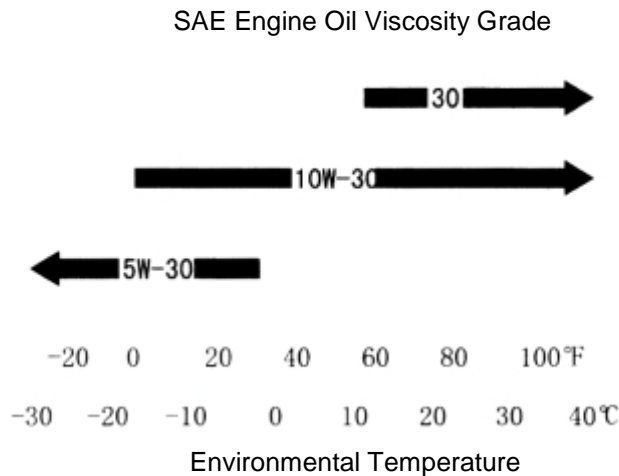

Checking the Air Filter

1. Remove the air filter cover, and check to see if the air filter is clean. If it is dirty, clean it.
2. After checking the air filter, reinstall the air filter cover.

Operating Instructions

Starting

1. The engine on the PGD2875 is inclinable, which means it can be stored and operated in any direction. BEFORE STARTING, the driver needs to be in the horizontal position for 5 minutes.
2. Before starting the post driver, press the transparent, semi-circle fuel bubble repeatedly until the carburetor is filled with fuel. If the engine is cool, place the choke lever to the "on" position.
3. Place one hand on the top engine cover with slight downward pressure. With your other hand, pull the starter rope about 20" quickly.
4. AFTER the engine has started, place the choke lever completely to the "off" position. AFTER IDLING FOR 5 MINUTES, start normal work.
5. While the post driver is running, don't pull the starter rope. The high-speed rotating parts may damage the starter.

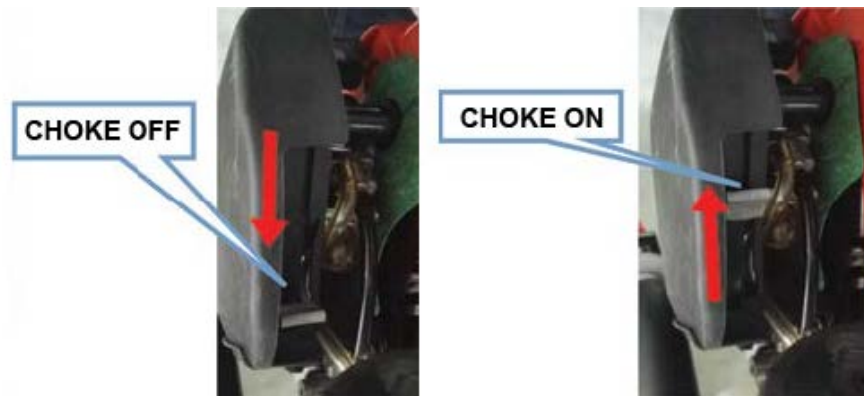

Operating

1. After the engine is started, ALLOW IT TO IDLE FOR 5 MINUTES BEFORE USE.
2. For a brand new driver, ONLY PERFORM LOW TO MEDIUM-SPEED WORK FOR THE FIRST 24 HOURS OF USE in order to break in the engine and prolong the life of the machine.
3. For a brand new driver, it may take 2 to 3 minutes of post driving for the machine to begin running at a normal performance level.
4. Do not operate the driver at a high speed when you are not driving posts.

Turning Off the Machine

1. Release the throttle trigger and ALLOW THE MACHINE TO IDLE FOR 3 TO 5 MINUTES.
2. Push the stop switch to the off position (see below).

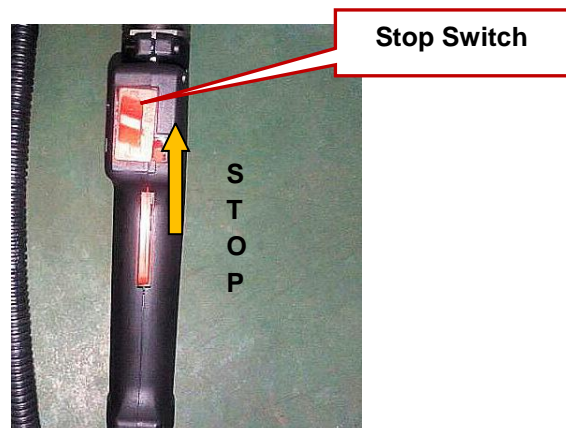

Service and Maintenance

Air Filter Maintenance

After the driver has been used for some time, dirt and dust particles can block the flow of air, which will result in reduced power and increased oil consumption. It is necessary to clean the air filter regularly. The cleaning cycle is usually every 3 months or every 25 hours of operation. When using the driver in extremely dusty environments, clean it every 10 hours or even every day.

Cleaning the Air Filter

1. Remove the air filter cover, and take out the air filter.
2. Put the air filter into water. Squeeze the water out of the filter and allow it to air dry.
3. Put it in clean oil and rub gently. Take it out and squeeze it dry.
4. After cleaning, assemble the air filter and the air filter cover.

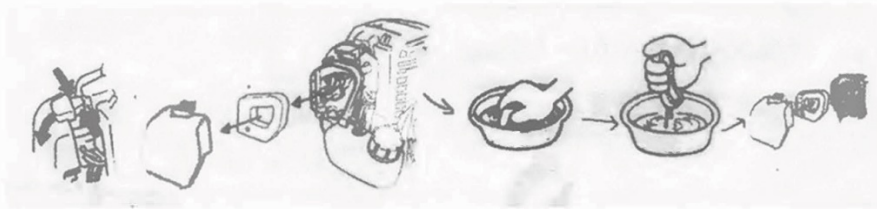

Fuel Filter Maintenance

If the fuel filter is blocked, the post driver will have reduced speed and weaker impact energy.

1. Open the tank lid.
2. Remove the fuel filter from the fuel tank with a metal hook and clean it.
3. When cleaning the fuel filter, clean the fuel tank at the same time as shown below.



Carburetor Maintenance

The fuel tank and the carburetor generally have residual fuel. Over time, the residual fuel can block up the fuel line causing the engine not to start. Therefore, when the machine is not used for more than one week, be sure to completely remove the fuel.

1. To drain fuel, remove the fuel inlet pipe and filter from the tank. Press the carburetor fuel bubble repeatedly until all fuel has been emptied from the lines and carburetor.
2. Empty out any fuel that has drained into the fuel tank, then place the fuel filter and line back inside the tank.

Spark Plug Maintenance

If the spark plug has too much carbon deposit, it will result in poor engine performance. It is necessary to regularly maintain and adjust the spark plug every year or every 100 hours of operation.

1. Remove the spark plug as shown.
2. Remove carbon deposit.
3. Adjust to 0.6 – 0.7 mm.
4. Replace the spark plug.

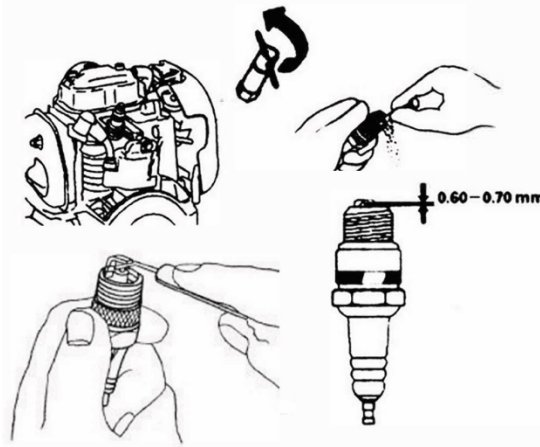

Replacing Engine Oil

1. Dirty engine oil will result in reduced service life of moving engine parts. It is necessary to regularly replace engine oil and keep engine oil at proper levels.
2. Replace engine oil every 6 months or after 50 hours of operation.
3. Drain the oil when the engine is hot to guarantee that engine oil can be emptied quickly and completely.
4. Replacing engine oil:
 - a. Ensure that the cap of the fuel tank is screwed tight.
 - b. Place a proper container near the engine for storing waste engine oil.
 - c. Remove the engine oil gauge, lean the engine toward the engine oil filler, and discharge engine oil to the container as shown below.
 - d. Place the driver horizontally and add the recommended oil to the bottom edge of the oil filler. Refer to pages 6 and 13 for adding the correct amount of engine oil.

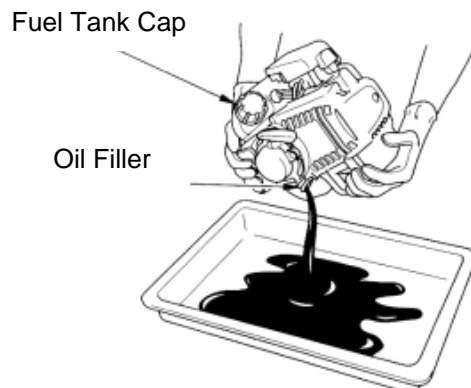

The recommended environmental temperature range of the machine is 5° to 105° F. We recommend the use of SAE 10W-30 engine oil, which equals to API classification SJ.

Lubrication of Gearbox and Impact Parts

After 40 hours of use, open the gearbox cover, and add 75 Series Grease to the connecting rod to fully lubricate the machine as shown below.



Maintenance Schedule

This schedule is based on operating the post driver under normal conditions. Under more strenuous conditions, such as a dusty environment or long work hours, the maintenance cycle should be adjusted accordingly.		Before Each Use	After Each Use or Every Day	After Filling Oil	Every Week	Every Month	If Temporary Failure	If Necessary
The Whole Machine	Outlook Check (state, tightness of screws)	√		√				
	Clean		√					
Control Handle/Stop Button	Function Check	√		√				
Air Filter	Clean				√			√
	Replace						√	
Fuel Filter	Check					√		
	Replace						√	
Fuel Tank/Fuel Tank Lid	Clean		√	√				
	Check	√		√				
	Tighten							√
Reduction Gearbox/Impact Cylinder	Clean					√		
	Add Grease							√
Muffler	Check					√		
	Remove Carbon Deposit							√
Cylinder Cooling Fin	Check					√		
	Clean							√
Spark Plug	Check/Adjust					√		
	Replace							√
Screw and Nut	Check	√		√				
	Tighten							√

Troubleshooting

Example 1: Difficulty starting the engine.

1. Make sure the choke lever is in the "on" position (page 7).
2. Remove the fuel in the tank, and replace it with fresh gasoline.
3. Press the fuel bubble 3-4 times.
4. Check to make sure the on/off switch is in the down position.
5. Check the fuel filter (page 8).
6. Check the air filter (page 8).
7. Check the spark plug (page 11).

Example 2: Difficulty starting after a sudden stop.

1. Check the fuel level.
2. Check to make sure the on/off switch is in the down position.
3. Check the fuel filter (page 8).
4. Check the spark plug (page 11).

Example 3: Engine lacks power.

1. Check the air filter (page 8).
2. Check the spark plug (page 11).
3. Check the fuel lines and fuel filter (page 8).

Example 4: Post driver is not performing efficiently.

1. Be sure to hold 10-12 pounds of downward pressure while driving posts.
2. Try different throttle positions to find the best speed for your application. Use the throttle limit screw to dial in the best throttle setting.
3. Check the driver impact grease level. 1-2 tablespoons max (page 10).
4. Check the condition of the O-rings.

Example 5: The starter rope will not pull.

1. Make sure the driver has been in the horizontal position for at least 5 minutes.
2. Check the engine oil.
 - a. If low, add oil.
 - b. If too full, remove excess oil and follow the steps below.

*If the driver was overfilled with oil, or engine was stored upside down for long periods of time, oil can seep into the combustion chamber and cause it to become hydrolocked. Follow the steps below to resolve this issue.

 - i. Remove the top cover from the engine.
 - ii. Remove the spark plug wire.
 - iii. Remove the spark plug.
 - iv. Place a small rag near the spark plug hole to catch any oil that may seep out.
 - v. Slowly pull the starter rope.
 - vi. Continue until all oil has been removed from the cylinder.

*WARNING: Oil may shoot from the spark plug hole as you pull the starter rope.

If these steps do not address your issue, call Titan Post Drivers at **(702) 293-4262** for further assistance.

Key Product Data

Engine Type	4-stroke, single-cylinder, air-cooled 140FA gasoline engine
Model	PGD2875
LxWxH (inches)	25" x 10" x 13"
Fuel	86 octane, unleaded gasoline or higher
Displacement	37.7 cc
Fuel Tank Volume	0.17 US gal
Oil Capacity	2.71 US oz
Weight	30 lbs
Max Power and Corresponding Rotating Speed	1.3 hp / 6,500 r/min
Max Torque and Corresponding Rotating Speed	1.2 ft/lb / 5,500 r/min
Fuel Consumption Rate	≤ 0.19 US gal/hr
Impact Frequency	1,500 – 2,000 bpm
Impact Energy	Up to 33 ft lbs
Carburetor Type	H129-1C4/H629-1C4
Spark Plug Type	CMR5H
Starter System	Hand-pull start

Exploded View of PGD2875 Driver

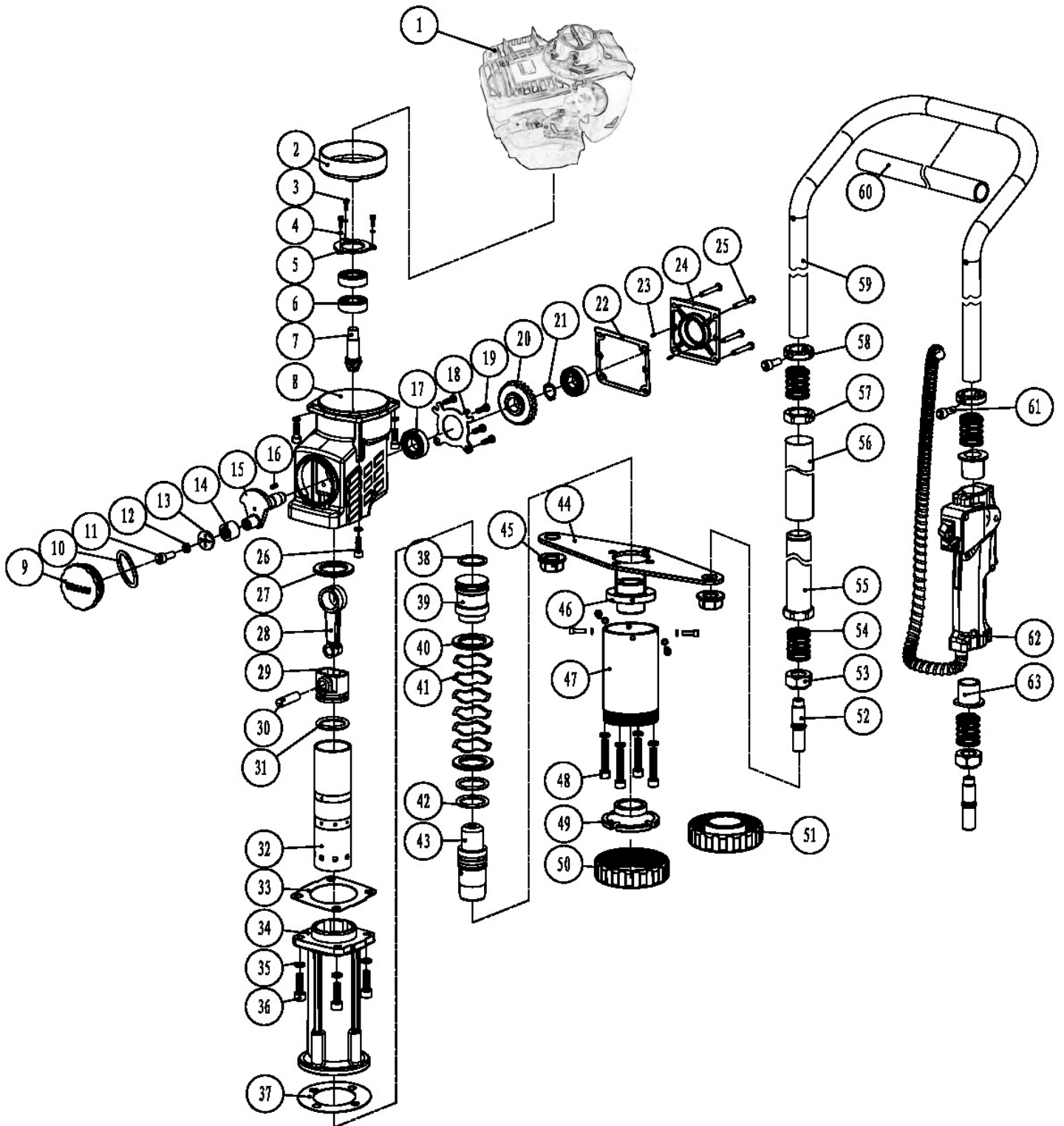

Parts List and Exploded View of PGD2875 Driver

No.	Part Name	Qty	No.	Part Name	Qty
1	140FA Gasoline Engine	1	26	Inner Hexagon Cylindrical-Head Screw M6x20	4
2	Driven Disk	1	27	Cylinder Gaskets	1
3	Inner Hexagon Cylindrical-Head Screw M5x12	3	28	Impact Connecting Rod	1
4	Elastic Washer 5	3	29	Impact Piston	1
5	Bearing Pressing Plate	1	30	Impact Piston Pin	1
6	Deep Groove Ball Bearings 6202-2RS	3	31	O-Ring Impact Piston	1
7	Small Bevel Gear 7-2	1	32	Impact Cylinder	1
8	Reduction Gearbox	1	33	Middle Paper Pad	1
9	Grease Cover	1	34	Hammer Case	1
10	O-Ring Grease Coverφ1.5x50	1	35	Elastic Washer 8	8
11	Inner Hexagon Cylindrical-Head Screw M6x16	1	36	Inner Hexagon Cylindrical-Head Screw M8x20	4
12	Elastic Washer 6	5	37	Front Paper Pad	1
13	Retainer	1	38	Hammer O-Ring	1
14	Needle Roller Bearings HK152316	1	39	Hammer	1
15	Crankshaft	1	40	Crush Pad	2
16	A-Type Common Flat Key 5x5x10	1	41	Waved Gasket φ39x46x0.5	6
17	Deep Groove Ball Bearings 6003-2RS	2	42	Shock O-Ring	2
18	6003 Bearing Pressing Plate	1	43	Shock	1
19	Cross Pan Head Screw M5x14	4	44	Support Plate	1
20	Large Bevel Gear 28-2	1	45	Hexagon Flange Nut M18x1.5	2
21	Shaft Retainer 16	1	46	Impact Socket	1
22	Rear Paper Pad	1	47	Piling Socket	1
23	Round Pin 4x10	2	48	Inner Hexagon Cylindrical-Head Screw M8x40	4
24	Reduction Gearbox Cover	1	49	Inner Pile Head 77	1
25	Inner Hexagon Cylindrical-Head Screw M5x20	4	50	Piling Socket Sleeve	1

No.	Part Name	Qty	No.	Part Name	Qty
51	Piling Socket Sleeve	1	63	Switch Handle Guide Sleeve	2
52	Connecting Thread Head	2			
53	Step Nut	2			
54	Handle Spring 38x27X ϕ 2.5	4			
55	Handle Sleeve	1			
56	Handle Soft Sleeve	1			
57	Handle Nut	1			
58	Positioning Sleeve	2			
59	Handle Frame	1			
60	Handle Frame Soft Sleeve	1			
61	Inner Hexagon Cylindrical-Head Screw M6x40	2			
62	Combination Switch	1			

Exploded View of 140FA Engine

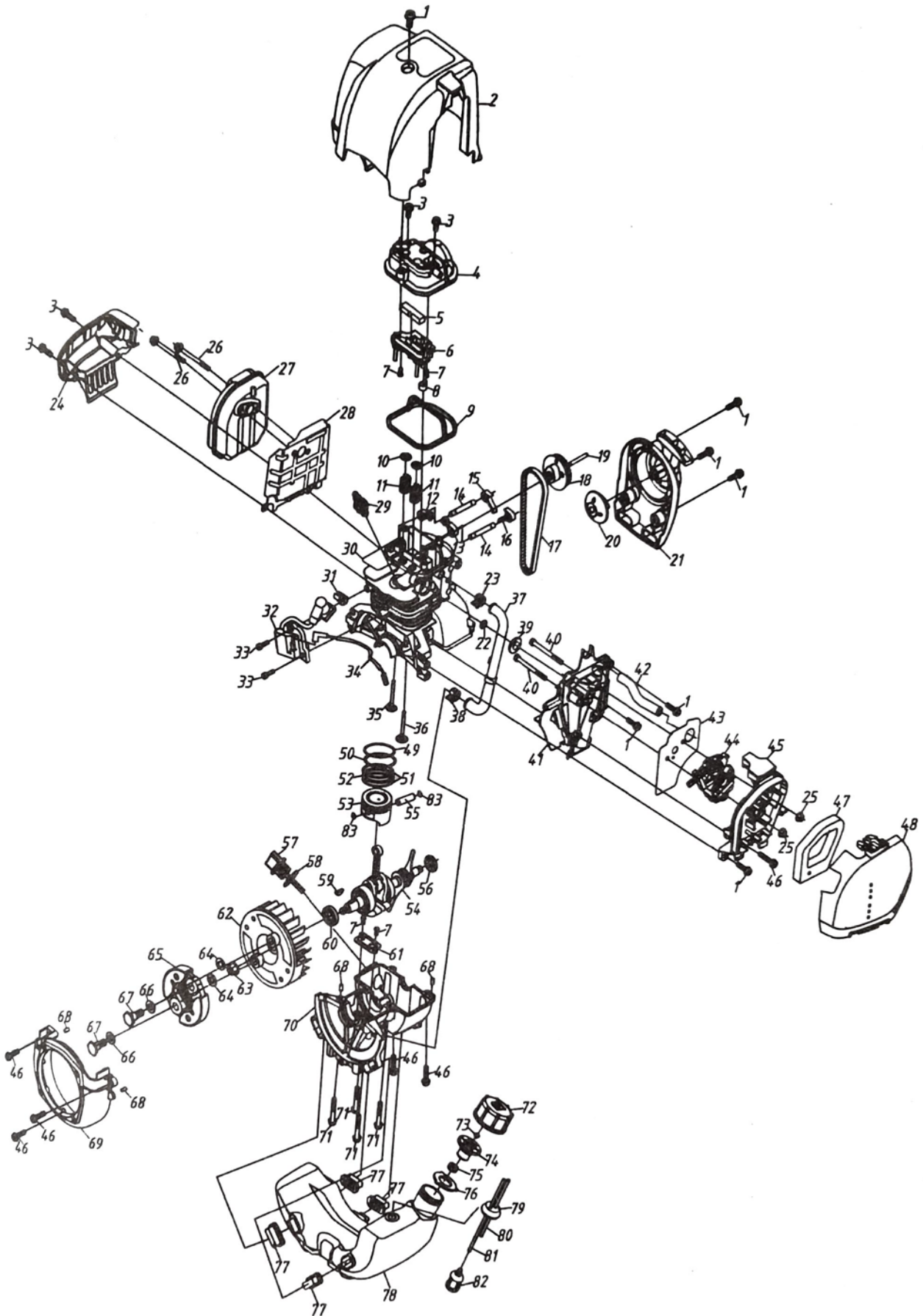

Parts List and Exploded View of 140FA Engine

Parts No.	Name	Qty	Parts No.	Name	Qty
1	Socket M5X15	7	43	Carburetor Gasket	1
2	Cover	1	44	Carburetor	1
3	Socket M5x12	3	45	Air Cleaner Housing	1
4	Cylinder Head Cover	1	46	Socket M5x22	6
5	Filter	1	47	Filter Element	1
6	Inner Head Cover	1	48	Air Cleaner Cover	1
7	Screw M4x8	4	49	First Piston Ring	1
8	Head Cover Grommet	1	50	Second Piston Ring	1
9	Head Cover Seal	1	51	Oil Rings	2
10	Valve Spring Retainer	2	52	Cushion Spring	1
11	Valve Spring	2	53	Piston	1
12	Exhaust Valve Rocker	1	54	Crankshaft Assembly	1
13	Intake Valve Rocker	1	55	Piston Pin	1
14	Rocker Arm Pin	2	56	Oil Seal	1
15	Exhaust Valve Lifter	1	57	Oil Level Gauge	1
16	Intake Valve Lifter	1	58	O-Shaped Seal Ring 14x2.65	1
17	Timing Belt	1	59	Woodruff Key 3x5x13	1
18	Cam Gear	1	60	Oil Seal	1
19	Cam Pin Roller	1	61	Oil Valve	1
20	Recoil Starter Pulley	1	62	Flywheel	1
21	Starter Assembly	1	63	Nut M8	1
22	Intake Pipe Flat Gasket	1	64	Spacer	2
23	Clamp	1	65	Clutch	1
24	Air Guide	1	66	Clutch Washer	2
25	Flange Nut M5	2	67	Clutch Bolt	1
26	Stud Bolt	2	68	Pin B4x8	4
27	Muffler	1	69	Fan Cover	1
28	Air Exhaust Guide	1	70	Lower Crankcase	1
29	Spark Plug	1	71	Socket M5x32	4
30	Cylinder Block	1	72	Fuel Tank Cap	1
31	Ignition Wire Clamp	1	73	Intake Nozzle	1
32	Ignition Coil Assembly	1	74	Inner Cap	1
33	Socket M4x14	2	75	End Cap	1
34	Stop Wire	1	76	Gasket	1
35	Exhaust Valve	1	77	Rubber Shock Absorber	4
36	Intake Valve	1	78	Fuel Tank	1
37	Oil Tube	1	79	Fuel Line Grommet	1
38	Clamp	1	80	Fuel Return Tube	1
39	Intake O-Ring	1	81	Fuel Inlet Tube	1
40	Bolt M5X55	2	82	Fuel Filter	1
41	Intake Shroud	1	83	Piston Pin Retainer	2
42	Breather Tube	1			

Warranty

Titan Post Drivers will warrant to the original purchaser, who purchases the equipment in new condition and in its original packaging from an authorized dealer, that its gas-powered post driver will be free from defects in workmanship and materials for a period of one (1) year. This warranty period will commence on the date of retail purchase by the original purchaser. This warranty is non-transferrable beyond the original purchaser.

- Warranty shall pertain to parts or service offered by an authorized Titan Post Drivers dealer. Any defective part replaced at an authorized Titan Post Drivers location becomes the property of Titan Post Drivers.
- Shipping costs to transport the machine to the service center for warranty work will be the responsibility of the consumer.
- Titan Post Drivers will pay for return shipping to the customer within the Contiguous US.
- For warranty claims, contact Titan Post Drivers with proof of purchase date and your serial number.

Limitations of Warranty

This limited warranty does not extend to any Titan Post Drivers product which has been misused, abused, or improperly maintained, altered, or repaired by an unauthorized person. Nor does this limited warranty cover any damage to machine or parts due to faulty installation of parts, faulty operation, or faulty maintenance. Plastic carrying cases and reducer sleeves are not covered under this warranty.

- Damage to components caused by operator error such as dry-fire or misfire will not be considered for warranty replacement or service.
- Damage to cosmetic parts caused by rough handling, operator error, or improper storage and handling will not be considered for warranty replacement or service.
- Excluded components that may need replacement or repair due to normal wear and tear, or lack of proper use/maintenance include:
 1. O-rings and seals
 2. Lost or stripped fasteners
 3. Barrel of driver from incorrect use of machine
 4. Titan Post Drivers sleeves/accessories

Disclaimer of Warranty

Titan Post Drivers disclaims all liability for any implied warranties. Under no circumstances shall Titan Post Drivers be liable for any loss of business, revenues, profit, or indirect, incidental, special, or consequential damages or loss arising out of any defect in, or performance of, Titan Post Drivers products, howsoever caused.



Contact:

Hours: Monday-Friday 8 AM to 5 PM CST

Address: 713 E Austin Blvd, Nevada, MO 64772

Phone: (702) 293-4262

Email: info@titanpostdrivers.com

TITAN
POST DRIVERS